



SANITARY CENTRIFUGAL PUMPS

CR series



HYGIENE BIOTECHNOLOGY INDUSTRIAL

Centrifugal pumps incorporating a special auger type screw shaped impeller, which is ideal for the gentle handling of very delicate fluids and large soft solids in suspension. Wetted parts in investment cast CF-3M 1.4404 / AISI 316L stainless steel, electro-chemically polished to ensure the perfect surface finish. Separate IEC standard motor. Stainless steel shroud and adjustable feet on request. The clamp casing and seal design allows quick disassembly for inspection, cleaning and maintenance. It also enables the delivery port to be rotated to any position for easy installation.

Delicate handling without clogging.
The CR Series has been designed for very gentle handling of sensitive media at extremely low flow velocities.



CR pump with shroud

The screw shape impeller combines the properties of a centrifugal pump with the delicate characteristics of a positive displacement pump. The ability to handle high solids products in an extremely gentle way makes CR Series pumps ideal for food processing: Fruit and vegetable handling, soups and sauces, cereals, fish transportation, food pastes, oil, wine recirculation.

TECHNICAL DATA

Flow rates up to 150 m³/h
Heads up to 20 m
Maximum operating pressure 10 bar up to 100°C
Temperature range -10°÷ +100°

Mechanical seals:

With seats to EN 12756, ISO 3069 standards.
Single internal mechanical seal
Single external mechanical seal
Double flushed mechanical seal

Elastomers (FDA Regulation (EC) No. 1935/2004):

Nitrile (NBR)
Ethylene propylene (EPDM)
Fluorocarbon seal (FPM - FKM)
FEP
FFPM - FFKM
Silicone

Connections:

DIN - SMS - IDF - BS / RJT - DS - CLAMP and
EN1092-1 PN16 flanges suitable for all international standards.



GENERAL DIAGRAMS

(Performance applies to H₂O at 20 °C, 1013 mbar, Data not binding)

POMPA TIPO Pump type		CR 65			n 920/1110	giri / min r. p. m.
GIRANTE — Impeller						
TIPO Type	N° di pale n° of vanes	Pass. sferico max. sphere	Ø max max. diameter	Ø min min. diameter	Bocche tipo Ports type	Bocca aspir. Suction port
APERTA	1 Elica	33 mm	156 mm	— mm	DIN 11851	DN 65
						Bocca mand. Discharge port
						DN 65
CARATTERISTICHE DI FUNZIONAMENTO CON ACQUA PULITA A 20°C - PESO SPECIFICO 1 (kg/dm ³) Curves show performance with clear water at 70°F - Specific gravity 1 (kg/dm ³)						

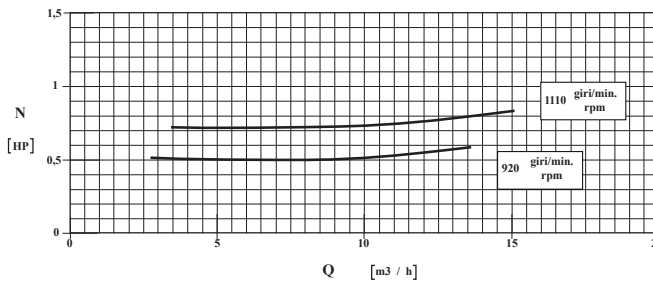
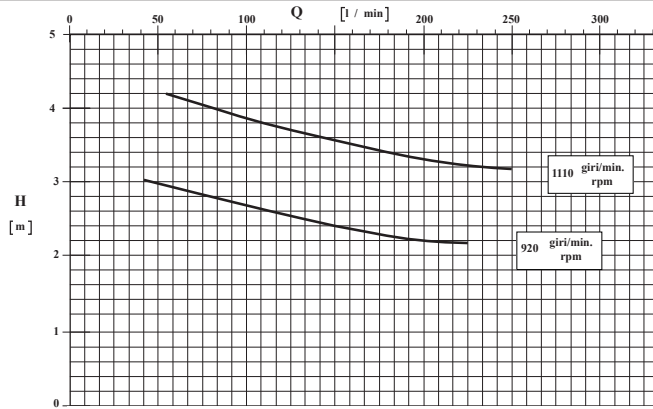

POMPA TIPO Pump type		CR 80			n 960/1150	giri / min r. p. m.
GIRANTE — Impeller						
TIPO Type	N° di pale n° of vanes	Pass. sferico max. sphere	Ø max max. diameter	Ø min min. diameter	Bocche tipo Ports type	Bocca aspir. Suction port
APERTA	1 Elica	45 mm	178 mm	— mm	DIN 11851	DN 80
						Bocca mand. Discharge port
						DN 80
CARATTERISTICHE DI FUNZIONAMENTO CON ACQUA PULITA A 20°C - PESO SPECIFICO 1 (kg/dm ³) Curves show performance with clear water at 70°F - Specific gravity 1 (kg/dm ³)						

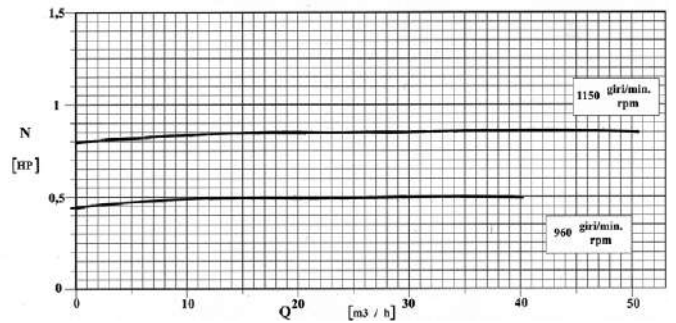
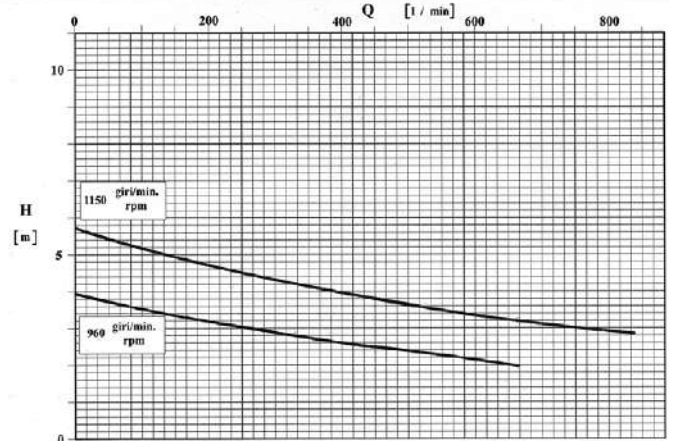

POMPA TIPO Pump type		CR 100			n 960/1150	giri / min r. p. m.
GIRANTE — Impeller						
TIPO Type	N° di pale n° of vanes	Pass. sferico max. sphere	Ø max max. diameter	Ø min min. diameter	Bocche tipo Ports type	Bocca aspir. Suction port
APERTA	1 Elica	58 mm	210 mm	— mm	DIN 11851	DN 100
						Bocca mand. Discharge port
						DN 100
CARATTERISTICHE DI FUNZIONAMENTO CON ACQUA PULITA A 20°C - PESO SPECIFICO 1 (kg/dm ³) Curves show performance with clear water at 70°F - Specific gravity 1 (kg/dm ³)						

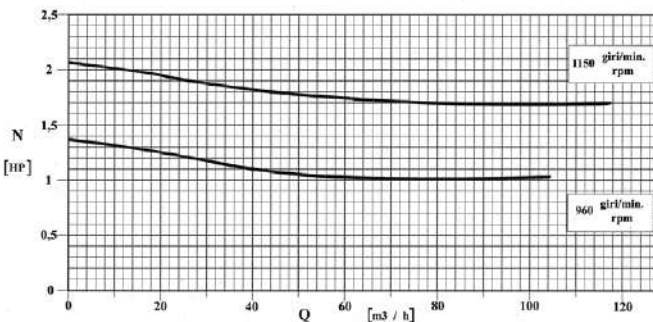
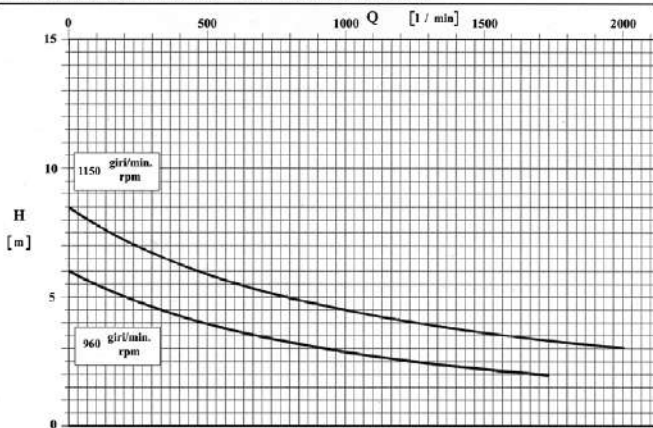

POMPA TIPO Pump type		CR 125			n 960/1150	giri / min r. p. m.
GIRANTE — Impeller						
TIPO Type	N° di pale n° of vanes	Pass. sferico max. sphere	Ø max max. diameter	Ø min min. diameter	Bocche tipo Ports type	Bocca aspir. Suction port
APERTA	1 Elica	63 mm	260 mm	— mm	DIN 11851	DN 125
						Bocca mand. Discharge port
						DN 125
CARATTERISTICHE DI FUNZIONAMENTO CON ACQUA PULITA A 20°C - PESO SPECIFICO 1 (kg/dm ³) Curves show performance with clear water at 70°F - Specific gravity 1 (kg/dm ³)						

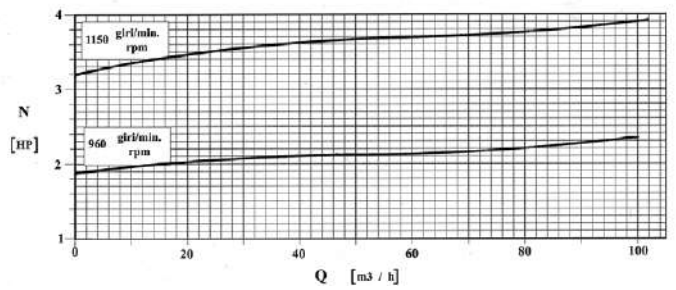
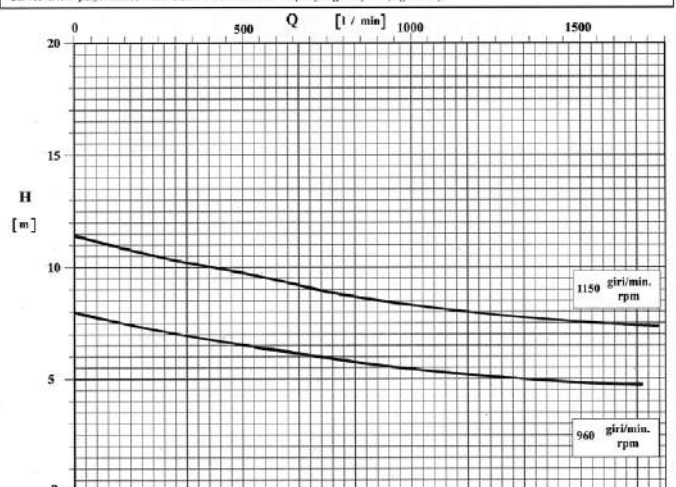

POMPA TIPO Pump type		CR 65			n 1400/1750 giri / min r. p. m.	
GIRANTE — Impeller						
TIPO Type	N° di pale n° of vanes	Pass. sferico max. sphere	Ø max max. diameter	Ø min min. diameter	Bocche tipo Ports type	Bocca aspir. Suction port
APERTA	1 Elica	33 mm	156 mm	---	DIN 11851	DN 65
					Bocca mand. Discharge port	DN 65
CARATTERISTICHE DI FUNZIONAMENTO CON ACQUA PULITA A 20°C - PESO SPECIFICO 1 (kg/dm ³) Curves show performance with clear water at 70°F - Specific gravity 1 (kg/dm ³)						

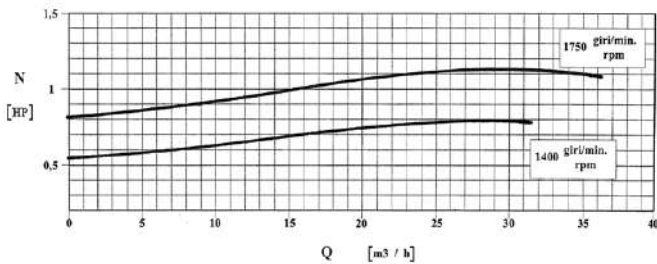
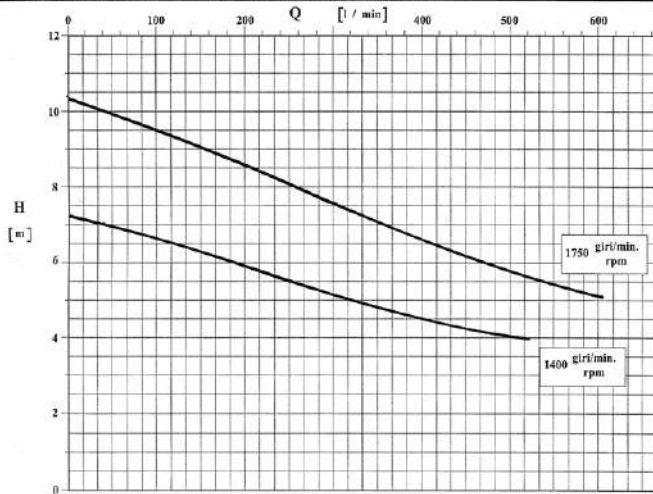

POMPA TIPO Pump type		CR 80			n 1450/1750 giri / min r. p. m.	
GIRANTE — Impeller						
TIPO Type	N° di pale n° of vanes	Pass. sferico max. sphere	Ø max max. diameter	Ø min min. diameter	Bocche tipo Ports type	Bocca aspir. Suction port
APERTA	1 Elica	45 mm	178 mm	---	DIN 11851	DN 80
					Bocca mand. Discharge port	DN 80
CARATTERISTICHE DI FUNZIONAMENTO CON ACQUA PULITA A 20°C - PESO SPECIFICO 1 (kg/dm ³) Curves show performance with clear water at 70°F - Specific gravity 1 (kg/dm ³)						

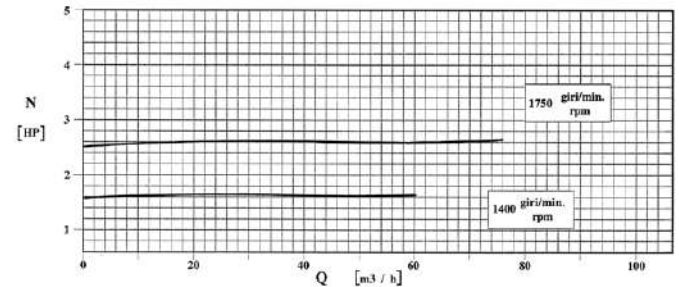
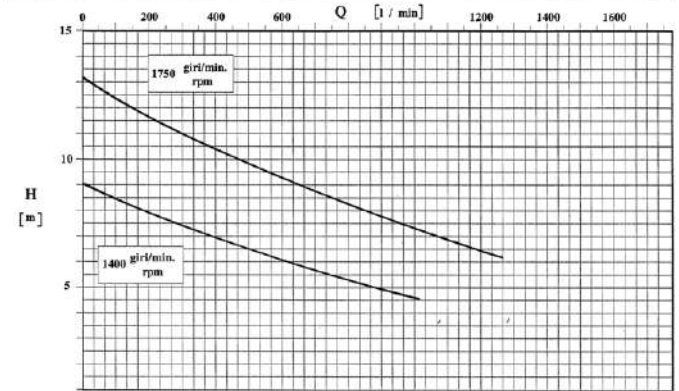

POMPA TIPO Pump type		CR 100			n 1450/1750 giri / min r. p. m.	
GIRANTE — Impeller						
TIPO Type	N° di pale n° of vanes	Pass. sferico max. sphere	Ø max max. diameter	Ø min min. diameter	Bocche tipo Ports type	Bocca aspir. Suction port
APERTA	1 Elica	58 mm	210 mm	---	DIN 11851	DN 100
					Bocca mand. Discharge port	DN 100
CARATTERISTICHE DI FUNZIONAMENTO CON ACQUA PULITA A 20°C - PESO SPECIFICO 1 (kg/dm ³) Curves show performance with clear water at 70°F - Specific gravity 1 (kg/dm ³)						

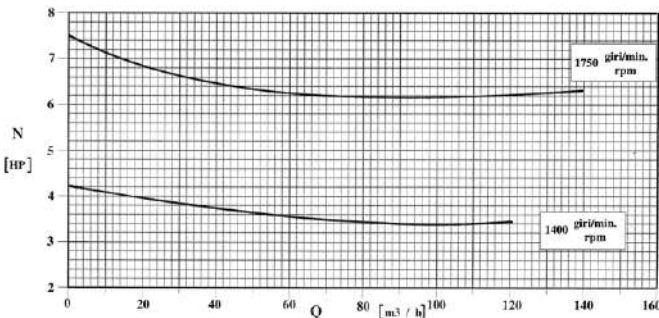
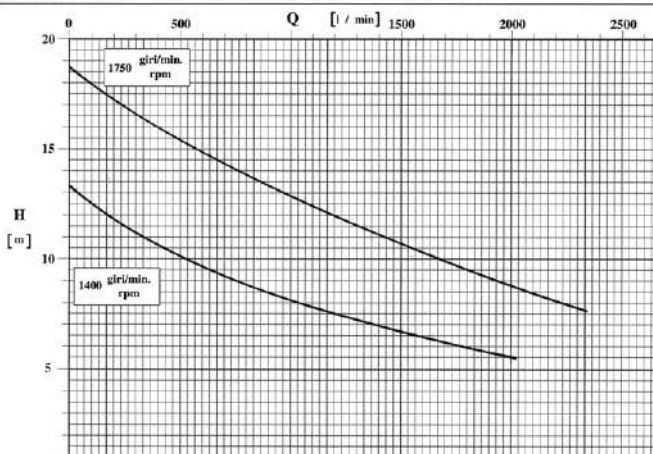

POMPA TIPO Pump type		CR 125			n 1450/1750 giri / min r. p. m.	
GIRANTE — Impeller						
TIPO Type	N° di pale n° of vanes	Pass. sferico max. sphere	Ø max max. diameter	Ø min min. diameter	Bocche tipo Ports type	Bocca aspir. Suction port
APERTA	1 Elica	63 mm	260 mm	---	DIN 11851	DN 125
					Bocca mand. Discharge port	DN 125
CARATTERISTICHE DI FUNZIONAMENTO CON ACQUA PULITA A 20°C - PESO SPECIFICO 1 (kg/dm ³) Curves show performance with clear water at 70°F - Specific gravity 1 (kg/dm ³)						

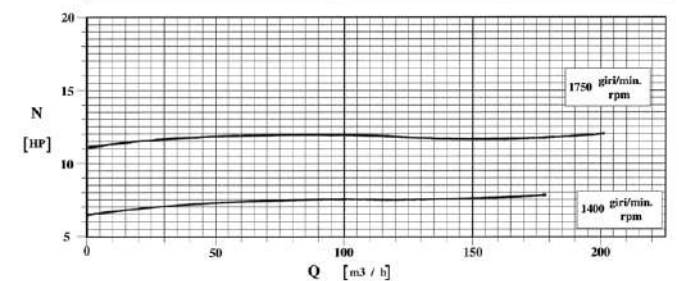
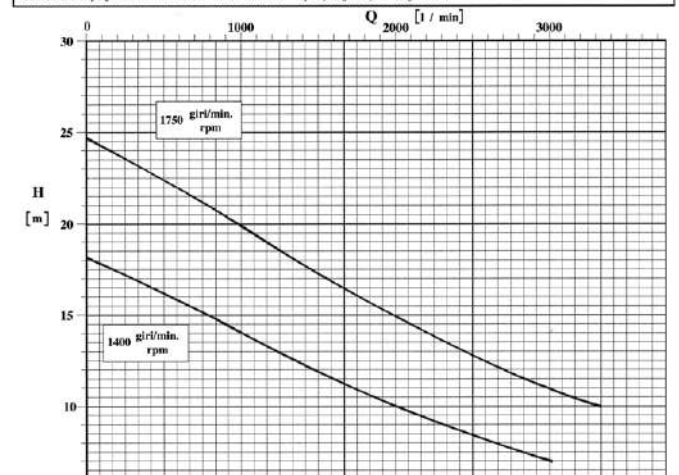

OVERALL DIMENSIONS

Dimensions not binding - DN = DIN 11851 male threaded connections, with standard IEC/EN motors

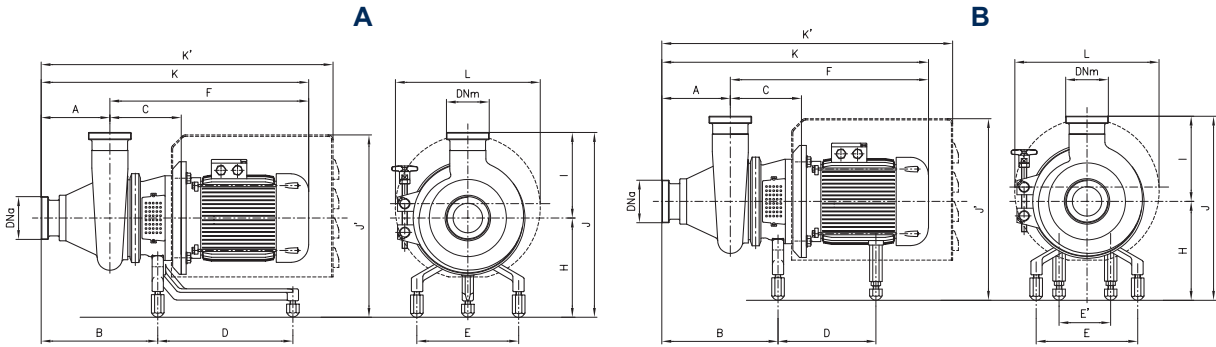

A = motors from 0,55 kW to 4 kW

Pump type	kW	DNa	DNm	A	B	C	D	E	E'	F	H	K	K'	I	J	J'	L
1450 rpm																	
CR 65	0,55	65	65	151	257	158	230	225	-	392	208	543	657	190	398	374	302
	0,75									437		588					
CR 80	1,1	80	80	181	297	168	300	225	-	452	230	632	767	245	458	379	302
	1,5									213		690					
	2,2									508		741					
CR 100	3	100	100	205	337	202	300	225	-	536	238	741	824	296	534	443	330
	4									536		741					

B = motors from 5,5 kW to 15 kW

Pump type	kW	DNa	DNm	A	B	C	D	E	E'	F	H	K	K'	I	J	J'	L
1450 rpm																	
CR 100	5,5	100	100	205	325	204	281,7	225	180	576	238	784	848	294	526	460	370
	7,5				326	249	319,7		230	727	247	932	1105		532	510	370
	11				326	249	408		230	727	247	932	1105		532	510	370
CR 125	15	125	125	232	370	230	281,7	225	180	604	238	836	900	346	584	501	430
	7,5				370	270	319,7		230	748	247	980	1035		593	510	
	11				370	270	412		230	748	247	980	1035		593	510	

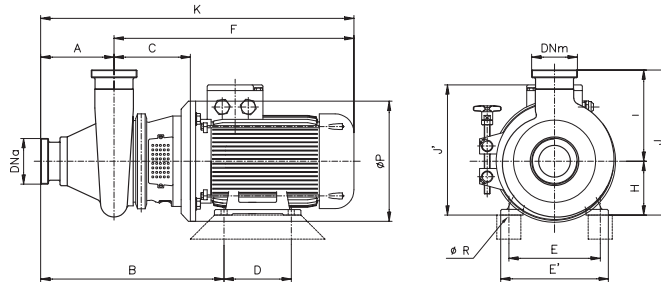

Pump type	kW	DNa	DNm	A	B	C	D	E	E'	F	H	K	I	J	J'	ØP	ØR			
1450 rpm																				
CR 65	0,55	65	65	151	360	158	100	125	150	392	80	543	190	270	200	200	10			
	0,75				362			140	165	437	90	588		280	218					
CR 80	1,1	80	80	181	406	168	125	140	165	452	90	632	245	335	218	200	10			
	1,5				413		160	196	481	100	663	345		235						
	2,2				413		190	226	502	112	684	357		260	250			12		
CR 100	3	100	100	205	477	202	140	190	240	515	112	720	294	406	331	250	12			
	4				497		178	216	256	576	132	781		426	299			300	12	
	5,5				570		257	210	190	240	734	160		937	454			357	350	15
	7,5				570		257	210	190	240	734	160		937	454			357	350	15
CR 125	11	125	125	232	550	230	140	216	256	604	132	836	346	478	404	300	12			
	15				610		270	210	254	300	748	160		980	506			432	350	15



C.S.F. Inox S.p.A. Strada per Bibbiano, 7 - 42027 Montecchio E. (RE) - ITALY EU

Ph +39.0522.869911 r.a. - Fx +39.0522.865454 - italia@csf.it - www.csf.it

Export Department • Commercial Étranger • Comercial Extranjero

Ph +39.0522.869922 - Fx +39.0522.869841 - export@csf.it - www.csf.it



All the instructions, data and representations (in whatever way executed) listed in this publication are indicative and do not binding. C.S.F. does not stand surety or undertake any obligation for the utilisation of this document and for the information contained. In particular, it does not guarantee against omissions or errors of the data and drawings here indicated. Notice that the technical specifications, information and representations in this document are merely indicative and approximate. C.S.F. INOX reserves the right at any moment and without notice to modify the data, drawings and information indicated in this document.