



TWIN SCREW PUMPS

TS series



HYGIENE BIOTECHNOLOGY INDUSTRIAL

The TS double screw volumetric pump is made entirely of stainless steel with contact surfaces designed according to the latest hygiene design requirements.

Suitable for major industrial applications such as in the food, dairy, cosmetic and pharmaceutical sectors, and for CIP washing and SIP sterilization processes.

Its construction makes it excellent for pumping delicate, viscous liquids, and products containing suspended solids, or for high viscosity fluids.

Suitable for high differential pressures, it has an excellent suction capacity and a reduced level of pulsations; no foaming even with high gas content.

Compact dimensions in relation to the performance provided, high volumetric efficiency, no contamination of the pumped product and no transfer of parts subject to wear.

The TS double screw pump is available in standard version with flexible coupling and motor, and in TSM close-coupled version.



PRODUCTS AND PROCESSES

Pumping applications

- Liquid food and beverages, dairy fluids, confectionery products, pharmaceutical and biotechnological fluids, cosmetics and fine chemicals.
- Fluids with suspended solids that must not be damaged.
- Fluids with suspended gas.

Typical products

- Food sector: fruit and vegetable juices, purees and concentrates, beverages also with suspended particles, syrups, spirits, chopped tomatoes, chopped vegetables, fruit salads, thick soups and gastronomic preparations, chocolate and custards ice creams.
- Dairy sector: milk, cream, soft cheeses, yogurt, curds, ricotta.
- Cosmetic and pharmaceutical sector: general pharmaceutical fluids, cosmetics, creams, gel and shampoos, detergents.



FEATURES

- All parts in contact with the product are made from AISI 316L stainless steel with surface finishes lower than Ra 0.8 micron. They are designed according to the latest hygiene design requirements. EHEDG/3A certified execution on request.



- Support entirely made of AISI 304 stainless steel.
- Shaft synchronisation by means of optimised spiral profile toothed wheels.
- High resistance stainless steel shafts supported by oil bath bearings.
- Single or double flushed, balanced hygienic mechanical seals.
- Connections series DIN 11851, 11864, Clamp (DIN o ISO), SMS, RJT, flanges and special accessories.
- EPDM, FPM and HNBR gaskets compliant with EU Reg. 1935/2004 and FDA; other materials on request.
- Motor shaft with key for coupling with flexible coupling to the motor drive.
- Wide range of optional accessories available to meet all market requirements, such as surface hardening treatments, stainless steel base or carriage installation, version with hollow space, by-pass, flow or pressure sensors.
- TSM close-coupled version available for some models.

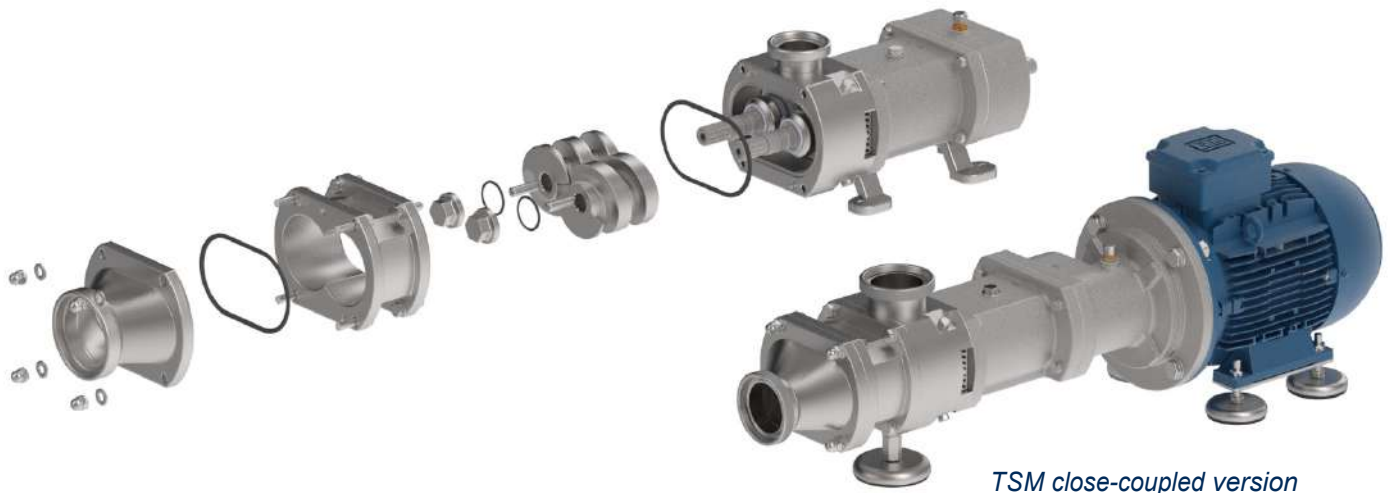

Available with different screw profiles to provide the best performance according to the type of installation.

- For high capacity
- For high pressure
- For delicate fluids with suspended solids

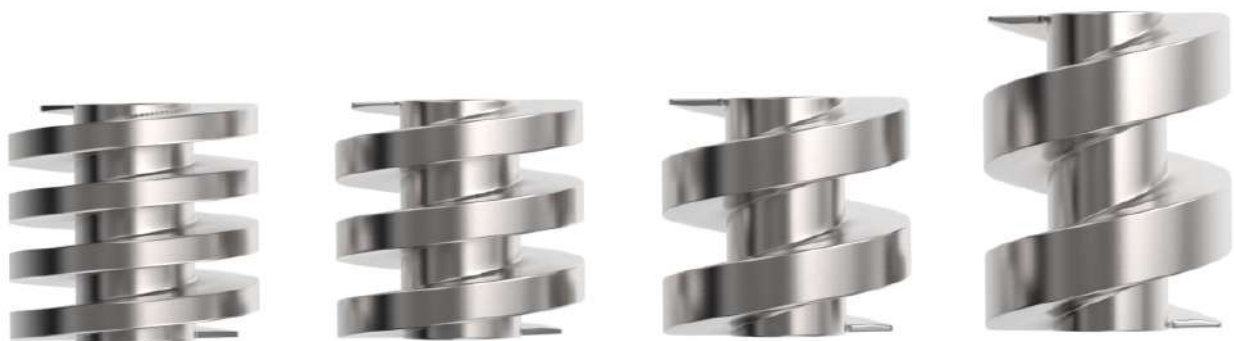

PERFORMANCE AND TECHNICAL DATA

Operating features with clean water at 20°C



Capacity 0 - 15 m³/h TSM50;
0 - 20 m³/h TS65-TSM65;
0 - 30 m³/h TS70-TSM70;
0 - 50 m³/h TS80;
0 - 80 m³/h TS90;
0 - 150 m³/h TS100.

Differential pressure up to 18 bar depending on the type of rotors.
Maximum operating pressure 25 bar (PN 25).
Temperature range -10°C ÷ 130°C.
Product viscosity up to 1.000.000 cP.

MECHANICAL SEALS

The TS range twin screw pumps can be supplied with different shaft seals according to the application:

A - SINGLE MECHANICAL SEAL



The single mechanical seal is a balanced hygienic cartridge type and is standard for low rotation speed applications and/or with non-viscous products.

MATERIALS:

- Silicon carbide / Silicon carbide
- Moulded gaskets in: EPDM, HNBR, FPM and, on request, FFKM

This execution can also be set up with an external cooling quench, using an optional radial seal ring.

B - DOUBLE FLUSHED MECHANICAL SEAL



The double mechanical seal is a balanced hygienic cartridge type. The ideal solution for all low speed applications with viscous process fluids and high rotational speed CIP processes.

MATERIALS:

- Silicon carbide / Silicon carbide
- Moulded gaskets in: EPDM, HNBR, FPM and, on request, FFKM

OVERALL DIMENSIONS

Dimensions not binding - DN = DIN 11851 male threaded connections with standard IEC/EN motors

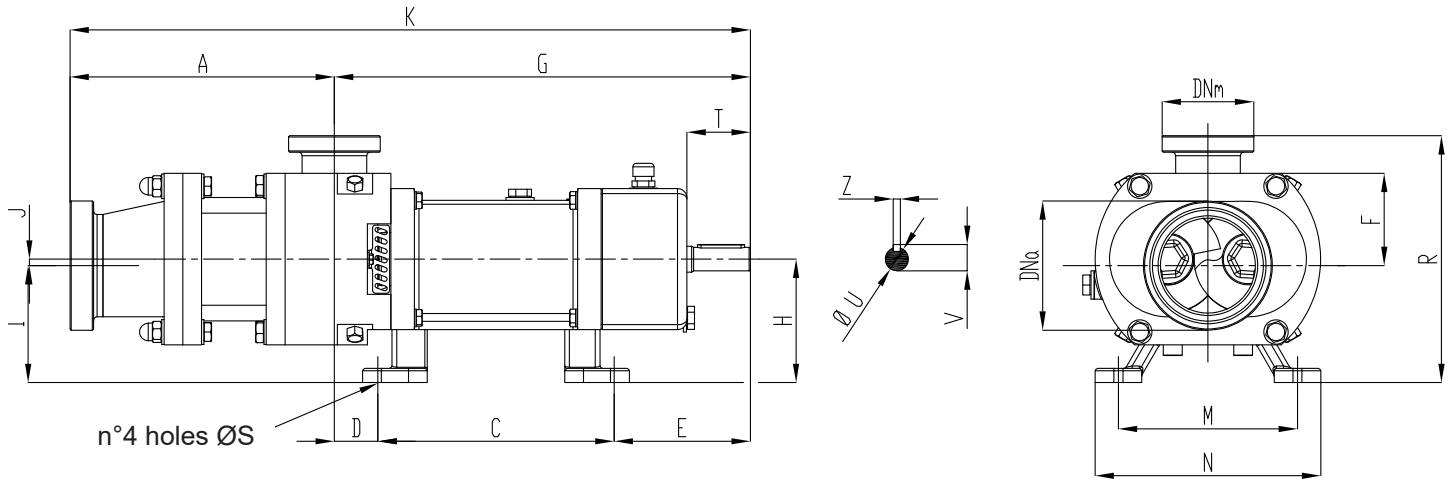

Pump type	DNa	DNm	A	C	D	E	F	G	H	I	J	K	M	N	R	S	T	U	V	Z
TS 65	80	65	225	201	37	116	78.5	354	105	99.5	5.5	579	152	192	215	11	54	20	22.5	6
TS 70	80	65	256	201	37	116	78.5	354	105	99.5	5.5	610	152	192	215	11	54	20	22.5	6
TS 80	100	80	280	283	18	134	104	435	177	163	14	715	287	340	309	17	71.5	32	35	10
TS 90	100	80	320	283	18	134	104	435	177	163	14	755	287	340	309	17	71.5	32	35	10
TS 100	125	100	395	321	35	216	147.5	572	191	163.5	27.5	967	287	340	363	17	129	45	48.5	14

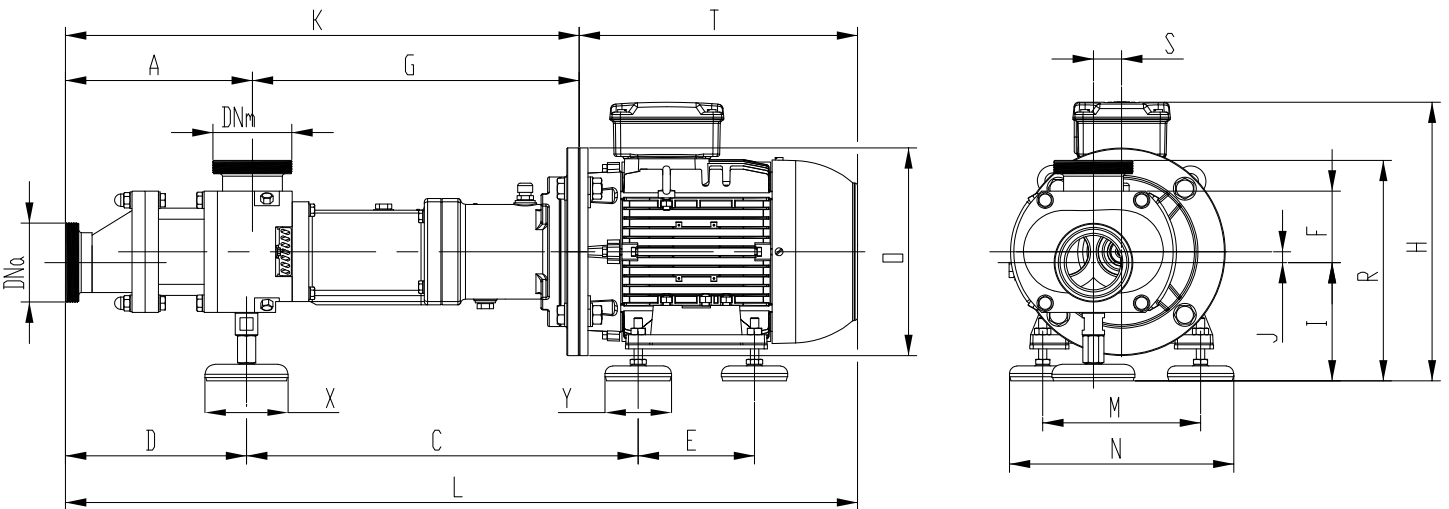

Pump type	IEC	DNa	DNm	A	C	D	E	F	G	H	I	J	L	K	M	N	R	S	O
TSM 50	100				386		140		327,5	309	145		884,6	524,5	172	232	239		250
	112	65	50	199	393	203,5	140	61	325,5	328	145	5	860,6	524,5	190	250	239	25	250
	132				433		178		306	383	168		956	505	216	276	262		200
TSM 65	100				466		140		309	137			979		172	252	260		250
	112	80	65	225	472,6	218	140	86	394,5	335	142,5	13	955	619,5	190	270	265,6	34	250
	132				492		178		381	159,5			1031		216	296	282,5		300
TSM 70	100				466		140		309	137			1009		172	252	260		250
	112	80	65	255	472,6	248	140	86	394,5	335	142,5	13	985	649,5	190	270	265,6	34	250
	132				492		178		381	159,5			1061		216	296	282,5		300

X: Ø80 TSM 50 ; Ø100 TSM 65-TSM 70

Y: Ø60 TSM 50 ; Ø80 TSM 65-TSM 70



C.S.F. Inox S.p.A. Strada per Bibbiano, 7 - 42027 Montecchio E. (RE) - ITALY EU

Ph +39.0522.869911 r.a. - Fx +39.0522.865454 - italia@csf.it - www.csf.it

Export Department • Commercial Étranger • Comercial Extranjero

Ph +39.0522.869922 - Fx +39.0522.869841 - export@csf.it - www.csf.it



All the instructions, data and representations (in whatever way executed) listed in this publication are indicative and do not bind. C.S.F. does not stand surety or undertake any obligation for the utilisation of this document and for the information contained. In particular, it does not guarantee against omissions or errors of the data and drawings here indicated. Notice that the technical specifications, information and representations in this document are merely indicative and approximate. C.S.F. INOX reserves the right at any moment and without notice to modify the data, drawings and information indicated in this document.